

---

# Service Manual

## **Latest HP ProBER 2 Information**

For the latest HP ProBER 2 information including Frequently Asked Questions, please refer to the following URLs on the WorldWide Web:

**<http://www.hp.com/go/prober>**

**<http://hpweb.sqf.hp.com/qto/support/supplayo.htm>**

(Scroll down until you reach Product Service Information and select HP E7580A ProBER.)

---

# HP ProBER 2



# Contents

## 1 General Information

|  |      |
|--|------|
| Warranty                                     | 1-2  |
| Responsibilities of the Customer             | 1-3  |
| Certification                                | 1-4  |
| Assistance                                   | 1-4  |
| Notice                                       | 1-4  |
| Restricted Rights Legend                     | 1-4  |
| Instrument Serial Number                     | 1-4  |
| Storage and Shipment                         | 1-5  |
| Repackaging for Shipment                     | 1-5  |
| Weight and Dimensions                        | 1-6  |
| Safety Precautions for the Operator          | 1-6  |
| Safety Symbols                               | 1-7  |
| Additional Precautions for Service Engineers | 1-8  |
| ESD Precautions                              | 1-8  |
| Operator's Maintenance                       | 1-9  |
| Cabinet Cleaning                             | 1-9  |
| Battery Replacement                          | 1-9  |
| Statement of Compliance                      | 1-10 |
| Australian EMC Regulations                   | 1-10 |
| Noise Declaration (German)                   | 1-10 |
| Electromagnetic Compatibility                | 1-10 |
| Declaration of Conformity                    | 1-11 |
| Specifications                               | 1-12 |

## 2 Performance Tests

|                               |     |
|-------------------------------|-----|
| Introduction                  | 2-2 |
| Equipment Required            | 2-2 |
| Performance Test Record       | 2-3 |
| Calibration Cycle             | 2-3 |
| Adjustments                   | 2-3 |
| Recall Default Settings       | 2-3 |
| Instrument Reset (Cold Start) | 2-4 |
| Self-Test                     | 2-4 |
| Internal Transmitter Clocks   | 2-5 |
| Transmitter Output            | 2-7 |

## Contents

Frequency Measurement and Looped Clock 2-10  
Jitter Measurement 2-13  
Performance Test Record 2-17

### **3 Repair**

Repair Policy 3-2  
Block Diagrams 3-2  
Troubleshooting 3-4  
Replacing the Battery 3-6  
Replacing the Board Assemblies 3-8  
    Replacing the Power Supply Board 3-9  
    Replacing the Processor Board 3-10  
    Replacing the Display Assembly 3-12  
Replaceable Parts 3-13

### **4 Calibration and Self-Test**

Pre-Calibration Procedure 4-2  
    Erasing Existing Calibration Data 4-2  
    Entering the Serial Number 4-2  
    Enabling Option 002 4-3  
    Setting the Time and Date 4-3  
Calibration 4-4  
    Test Equipment 4-4  
    Accessing the Calibration Menu 4-4  
    Calibration Test Equipment Setup 4-5  
Self-Test 4-6  
    Speaker/Microphone Test 4-6

---

## **1 General Information**

This section includes essential safety information for both operators and service engineers, as well as full specifications for HP ProBER 2.

## General Information

---

### Warranty

| HP Product  | Duration of Warranty |
|-------------|----------------------|
| HP ProBER 2 | 1 year               |

- 1 HP warrants HP hardware, accessories and supplies against defects in materials and workmanship for the period specified above.

If HP receives notice of such defects during the warranty period, HP will, at its option, either repair or replace products which prove to be defective. Replacement products may be either new or like-new.
- 2 HP warrants that HP software will not fail to execute its programming instructions, for the period specified above, due to defects in material and workmanship when properly installed and used.

If HP receives notice of such defects during the warranty period, HP will replace software media which does not execute its programming instructions due to such defects.
- 3 HP does not warrant that the operation of HP products will be uninterrupted or error free.

If HP is unable, within a reasonable time, to repair or replace any product to a condition as warranted, customer will be entitled to a refund of the purchase price upon prompt return of the product.
- 4 HP products may contain remanufactured parts equivalent to new in performance or may have been subject to incidental use.
- 5 The warranty period begins on the date of delivery or on the date of installation if installed by HP. If customer schedules or delays HP installation more than 30 days after delivery, warranty begins on the 31st day from delivery.
- 6 Warranty does not apply to defects resulting from (a) improper or inadequate maintenance or calibration, (b) software, interfacing, parts or supplies not supplied by HP, (c) unauthorized modification or misuse, (d) operation outside of the published environmental specifications for the product, or (e) improper site preparation or maintenance.
- 7 TO THE EXTENT ALLOWED BY LOCAL LAW, THE ABOVE WARRANTIES ARE EXCLUSIVE AND NO OTHER WARRANTY OR CONDITION, WHETHER WRITTEN OR ORAL, IS EXPRESSED OR IMPLIED AND HP SPECIFICALLY DISCLAIMS ANY IMPLIED WARRANTIES OR CONDITIONS OF MERCHANTABILITY,

## General Information

SATISFACTORY QUALITY, AND FITNESS FOR A PARTICULAR PURPOSE.

- 8** HP will be liable for damage to tangible property per incident up to the greater of \$300,000 or the actual amount paid for the product that is the subject of the claim, and for damages for bodily injury or death, to the extent that all such damages are determined by a court of competent jurisdiction to have been directly caused by a defective HP product.
- 9** TO THE EXTENT ALLOWED BY LOCAL LAW, THE REMEDIES IN THIS WARRANTY STATEMENT ARE CUSTOMER'S SOLE AND EXCLUSIVE REMEDIES. EXCEPT AS INDICATED ABOVE, IN NO EVENT WILL HP OR ITS SUPPLIERS BE LIABLE FOR LOSS OF DATA OR FOR DIRECT, INCIDENTAL, SPECIAL, CONSEQUENTIAL (INCLUDING LOST PROFIT OR DATA), OR OTHER DAMAGE, WHETHER BASED IN CONTRACT, TORT, OR OTHERWISE.

FOR CONSUMER TRANSACTIONS IN NEW ZEALAND AND AUSTRALIA: THE WARRANTY TERMS CONTAINED IN THIS STATEMENT, EXCEPT TO THE EXTENT LAWFULLY PERMITTED, DO NOT EXCLUDE, RESTRICT OR MODIFY AND ARE IN ADDITION TO THE MANDATORY STATUTORY RIGHTS APPLICABLE TO THE SALE OF THIS PRODUCT TO YOU.

## Responsibilities of the Customer

The customer shall provide:

- 1** Access to the products during the specified periods of coverage to perform maintenance.
- 2** Adequate working space around the products for servicing by Hewlett-Packard personnel.
- 3** Access to and use of all information and facilities determined necessary by Hewlett-Packard to service and/or maintain the products. (Insofar as these items may contain proprietary or classified information, the customer shall assume full responsibility for safeguarding and protection from wrongful use.)
- 4** Routine operator maintenance and cleaning as specified in the Hewlett-Packard Operating and Service Manuals.
- 5** Consumables such as paper, disks, magnetic tapes, ribbons, inks, pens, gases, solvents, columns, syringes, lamps, septa, needles, filters, frits, fuses, seals, detector flow cell windows, etc.

## **General Information**

### **Certification**

Hewlett-Packard Company certifies that this product met its published specifications at the time of shipment from the factory. Hewlett-Packard further certifies that its calibration measurements are traceable to the United States National Bureau of Standards, to the extent allowed by the Bureau's calibration facility and to the calibration facilities of other International Standards Organization members.

### **Assistance**

Product maintenance agreements and other customer assistance agreements are available for Hewlett-Packard products.

### **Notice**

The information contained in this document is subject to change without notice.

Hewlett-Packard shall not be liable for errors contained herein or for incidental or consequential damages in connection with the furnishing, performance or use of this material.

This document contains proprietary information which is protected by copyright. All rights are reserved. No part of this document may be photocopied or reproduced without the prior written consent of the manufacturer, Hewlett-Packard Ltd.

### **Restricted Rights Legend**

Use, duplication, or disclosure by the government is subject to restrictions as set forth in subdivision (b)(3)(ii) of the Rights in Technical Data and Computer Software clause at 52.227-7013. Hewlett-Packard Company; 3000 Hanover Street; Palo Alto, California 94304.

---

## **Instrument Serial Number**

Attached to the lower shell of the instrument is a serial number label on which is a two-letter reference denoting country of origin (GB = Great Britain) and an eight-digit serial number. The serial number is unique to each instrument and should be quoted in all correspondence with Hewlett-Packard, especially when ordering replacement parts.



## General Information



### Serial Number Plate

---

## Storage and Shipment

HP ProBER 2 may be stored or shipped in environments within the following limits:

**Temperature:** 0 to +55°C.

**Altitude:** Up to 15,200 meters (50,000 feet).

HP ProBER 2 should also be protected from temperature extremes which could cause condensation within the instrument.

## Repackaging for Shipment

**Tagging for Service.** If the instrument is being returned to Hewlett-Packard for service, please complete a repair tag and attach it to the instrument.

**Original Packaging.** Containers and materials identical to those used in factory packaging are available from Hewlett-Packard offices. If the instrument is being returned to Hewlett-Packard for servicing, attach a tag indicating the type of service required, return address, model number, and full serial number. Mark the container FRAGILE to ensure careful handling. In any correspondence, refer to the instrument by model number and full serial number.

**Other Packaging.** The following general instructions should be followed when repackaging with commercially available materials:

- Wrap instrument in heavy paper or plastic. If the instrument is being shipped to Hewlett-Packard, attach a tag indicating the type of service required, return address, model number and full serial number.

## General Information

- Use a strong shipping container. A double wall carton made of 350 pound test material is adequate.
- Use a layer of shock absorbing material 70 to 100 mm (3 to 4 in) thick, around all sides of the instrument to provide firm cushioning and prevent movement inside the container. Protect the controls and connectors with cardboard.
- Seal shipping container securely.
- Mark shipping container FRAGILE to ensure careful handling.
- In any correspondence, refer to instrument by model number and full serial number.

---

## Weight and Dimensions

**Weight:** 1 kg (2.2 lb) fully loaded.

**Dimensions:** 275 mm (10.8 in) high, 127 mm (5.0 in) wide, 55 mm (2.2 in) deep.

---

## Safety Precautions for the Operator

The following general safety precautions must be observed during all phases of operation, service, and repair of this instrument. Failure to comply with these precautions or with specific warnings elsewhere in this manual violates safety standards of design, manufacture, and intended use of the instrument. Hewlett-Packard Company assumes no liability for the customer's failure to comply with these requirements.

In particular, the operator should note the following safety information:

- "Safety Symbols" on page 1-7.
- "Connecting to the ac Power Supply" in the User Guide.
- "Operating Environment" in the User Guide.
- "Replacing the Battery" on page 3-6.
- "Operator's Maintenance" on page 1-9.

## General Information

**DO NOT** operate damaged equipment: Whenever it is possible that the safety protection features built into this product have been impaired, either through physical damage, excessive moisture, or any other reason, **REMOVE POWER** and do not use the product until safe operation can be verified by service-trained personnel. If necessary, return the product to a Hewlett-Packard Sales and Service Office for service and repair to ensure the safety features are maintained.

## Safety Symbols

The following symbols on the instrument and in the manual indicate precautions which must be taken to maintain safe operation of the instrument.



The product is marked with this symbol when it is necessary for the user to refer to the instructions in the supplied documentation.



Indicates the field wiring terminal that must be connected to earth ground before operating the equipment - protects against electrical shock in case of fault.

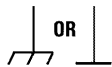

Frame or chassis ground terminal - typically connects to the equipment's metal frame.



Alternating current (ac).



Direct current (dc).



Indicates hazardous voltages.



Equipment protected throughout by Double Insulation or Reinforced Insulation, equivalent to Class II of IEC 536.

## General Information

---

### WARNING

---

Warning denotes a hazard. It calls attention to a procedure, which if not correctly performed or adhered to could result in injury or loss of life. Do not proceed beyond a warning until the indicated conditions are fully understood and met.

---

### CAUTION

---

Caution denotes a hazard. It calls attention to a procedure, which if not correctly performed or adhered to could result in damage to or destruction of the instrument. Do not proceed beyond a caution until the indicated conditions are fully understood and met.

---

## Additional Precautions for Service Engineers

**DO NOT** substitute parts or modify equipment: Because of the danger of introducing additional hazards, do not install substitute parts or perform any unauthorized modification to the product. Return the product to a Hewlett-Packard Sales and Service Office for service and repair to ensure the safety features are maintained.

**DO NOT** service or adjust alone: Under certain conditions, dangerous voltages may exist even with the equipment switched off. To avoid dangerous electrical shock, service personnel must not attempt internal service or adjustment unless another person, capable of rendering first aid and resuscitation, is present.

---

## ESD Precautions

---

### CAUTION



When connecting or disconnecting HP ProBER 2, ensure that you are grounded to bring you and the instrument to the same static potential.

HP ProBER 2 contains components sensitive to electrostatic discharge. To prevent component damage, carefully observe the handling precautions that follow.

## General Information

The smallest static voltage most people can feel is about 3500 V. It takes less than one tenth of that (about 300 V) to destroy or severely damage static sensitive circuits. Often, static damage does not immediately cause a malfunction but significantly reduces the component's life. Adhering to the following precautions will reduce the risk of static discharge damage.

- Keep HP ProBER 2 in its conductive storage box (the one it was shipped in) when not in use. Save this box for future storage of the unit. Alternatively, keep it in its soft carrying case (Option 020) if this was ordered with the instrument.
- Before handling HP ProBER 2, select a work area where potential static sources are minimized. Avoid working in carpeted areas and non-conductive chairs. Keep body movement to a minimum. Hewlett-Packard recommends that you use a controlled static workstation.
- Hold HP ProBER 2 by its handle. Avoid touching any components or edge connectors.

### Anti-Static Products

The following anti-static products are available from Hewlett-Packard:

- Anti-static workstation - Part Number 9300-0792
- Wrist-Strap and cord - Part Number 9300-0970

---

## Operator's Maintenance

Maintenance appropriate for the operator is:

- Cabinet cleaning.
- Battery replacement.

### Cabinet Cleaning

Clean the cover using a damp cloth only.

### Battery Replacement

See "Replacing the Battery" on page 3-6.

---

**WARNING**

**REFER SERVICING TO QUALIFIED PERSONNEL.**

## General Information

---

### Statement of Compliance

This instrument has been designed and tested in accordance with IEC Publication 1010-1 + A1:1992 Safety Requirements for Electrical Equipment for Measurement, Control and Laboratory Use, and has been supplied in a safe condition. The instruction documentation contains information and warnings which must be followed by the user to ensure safe operation and to maintain the instrument in a safe condition.



The CE mark shows that the product complies with all relevant European legal Directives.

**ISM 1-A**

This is a symbol of an Industrial Scientific and Medical Group 1 Class A product.

### Australian EMC Regulations



The C-Tick mark is a registered trademark of the Spectrum Management Agency of Australia. This signifies compliance with the Australian EMC Framework Regulations under the terms of the Radiocommunications Act of 1992.

### Noise Declaration (German)

LpA < 70 dB

am Arbeitsplatz (operator position)

normaler Betrieb (normal position)

nach DIN 45635 pt.19 (per ISO 7779)

---

### Electromagnetic Compatibility

HP ProBER 2 has been designed to meet the protection requirements of the European Communities Electromagnetic Compatibility (EMC) directive 89/336/EEC. In order to preserve the EMC performance of the product, any cable which becomes worn or damaged must be replaced with the same type and specification.

## General Information

# Declaration of Conformity

| <b>Declaration of Conformity</b>  |  |   |
|---|--|---|
| according to ISO/IEC Guide 22 and EN45014   |  |   |
| <b>Manufacturer's Name:</b>   | <b>Hewlett-Packard Ltd.</b>  |   |
| <b>Manufacturer's Address</b>   | Telecomms Networks Test Division<br>South Queensferry<br>West Lothian, EH30 9TG<br>Scotland, United Kingdom  |   |
| Declares that the product   |  |   |
| <b>Product Name:</b>  | ProBER 2, 2 Mb/s Handheld Test Set   |   |
| <b>Model Number:</b>  | HP E7580A  |   |
| <b>Product Options:</b>   | This declaration covers all options of the above product as detailed in TCF A-5951-9852-01   |   |
| Conforms with the protection requirements of European Council Directive 89/336/EEC on the approximation of the laws of the member states relating to electromagnetic compatibility, against EMC test specifications EN 55011:1991 (Group 1, Class A) and EN 50082-1:1992. |  |   |
| <b>As Detailed in:</b>  | Electromagnetic Compatibility (EMC)<br>Technical Construction File (TCF) No. A-5951-9852-01  |   |
| <b>Assessed by:</b>   | DTI Appointed Competent Body<br>EMC Test Centre,<br>GEC-Marconi Avionics Ltd.,<br>Maxwell Building,<br>Donibristle Industrial Park, Hillend,<br>Dunfermline KY11 9LB<br>Scotland, United Kingdom |   |
| Technical Report Number:6893/2200/CBR, dated 21 August 1997   |  |   |
| <b>Supplementary Information:</b>   | The product conforms to the following safety standards:<br>EN 61010-1(1993)<br>IEC 61010-1(1990) +A1(1992) +A2(1995)<br>CSA-C22.2 No. 1010.1-93<br>EN 60825-1(1994) / IEC 825-1(1993)            |   |
| The product herewith complies with the requirements of the Low Voltage Directive 73/23/EEC, and carries the CE marking accordingly.   |  |   |
| <i>South Queensferry, Scotland</i>  | <i>14 April 1999</i>   |  |
| <i>Location</i>   | <i>Date</i>  | <i>W.R. Pearson / Quality Manager</i>   |

Europe Contact:  
Your Local Hewlett-Packard Sales and Service Office or Hewlett-Packard GmbH, Department 2Q / Standards  
Europe, Herrenberger Strasse 130, D7030 Boblingen (Fax: +49-7031-143143)

## General Information

---

## Specifications

Except where otherwise stated, the following parameters are warranted performance specifications. Parameters described as “typical” or “nominal” are supplemental characteristics which provide a useful indication of typical but non-warranted performance characteristics.

### Transmitter

**Bit rate:** 2.048 Mb/s.

**Line code:** HDB3 or AMI.

#### Connectors:

BNC nominal 75Ω unbalanced.

3-pin Siemens nominal 120Ω balanced.

#### Mark level:

75Ω unbalanced - 2.37 V±10%.

120Ω balanced - 3.0 V±10%.

**Clock source:** Internal, recovered, external.

**Internal clock accuracy:** ±4.6 ppm.

**Recovered clock range:** 2.048 Mb/s ±100 ppm.

**External clock:** As ITU-T G.703 Section 10 (Reference 1). Will not operate if derived from coded (HDB3/AMI) source.

**Clock frequency offset:** Preset, user.

**Preset offset:** ±50 ppm.

**User offset:** ±100 ppm in 1 ppm steps.

### Test patterns

**PRBS:** 2<sup>9</sup>-1, 2<sup>11</sup>-1, 2<sup>15</sup>-1, 2<sup>20</sup>-1, 2<sup>23</sup>-1 as per ITU-T O.151, O.152, O.153.

**Word:** User-defined 8-bit word, user-defined 16-bit word, all-ones, all-zeros, 1010, 1000.

**Voice channel insert:** Single tone, DTMF dialling.

**Tone frequency:** 300 Hz to 3400 Hz in 1 Hz steps.

**Tone level:** -40 dB to -20 dB in 5dB steps; -20 dB to +3 dB in 1 dB steps.

**Error add:** Bit, FAS, CRC4, Code, E-Bit.

**Bit, CRC4, Code, E-Bit rate:** Single, 1 in 10<sup>3</sup>, 1 in 10<sup>4</sup>, 1 in 10<sup>5</sup>, 1 in 10<sup>6</sup>, 1 in 10<sup>7</sup>.

**FAS rate:** 1 frame error in 4 framing words, 2 in 4, 3 in 4, 4 in 4.

**Alarm generation:** LOS, AIS, LOF, TS AIS, RDI, RDI MF.

**Background fill signal:** Each background timeslot comprises a fixed byte which contains a number relating to its position in the 2 Mb/s structure.



## General Information

**Framing:** Standard (PCM31),  
CRC4 multiframe (PCM31CRC),  
standard with timeslot 16 CAS multiframe (PCM30),  
CRC4 multiframe with timeslot 16 CAS multiframe (PCM30CRC).

### User defined framing bits

**PCM31, PCM31CRC:** Remote alarm, spare bits (As per ITU-T G.704 reference 2).

**PCM30, PCM30CRC:** Remote alarm, remote CAS alarm, ABCD signaling bits,  
spare bits (As per ITU-T G.704 reference 2).

### Unframed

### Receiver

**Bit rate:** 2.048 Mb/s.

### Connectors:

BNC 75Ω unbalanced.

3-pin Siemens 120Ω balanced.

### Bridged Input:

Unbalanced 1.2 kΩ (nominal).

Balanced 1 kΩ (nominal).

**Line code:** HDB3 or AMI.

### Mark level:

75Ω unbalanced - 2.37 V peak.

120Ω balanced - 3.0 V peak.

**Return loss:** As ITU-T G.703 (Reference 1).

**Clock capture range:** 2.048 Mb/s ±100 ppm.

### Test patterns

**PRBS:** 2<sup>9</sup>-1, 2<sup>11</sup>-1, 2<sup>15</sup>-1, 2<sup>20</sup>-1, 2<sup>23</sup>-1.

**Word:** User-defined 8-bit word, user-defined 16-bit word, all-ones, all-zeros, 1010, 1000.

**Live traffic:** No test pattern expected during in-service measurements.

**n x 64 kb/s:** Contiguous or non-contiguous timeslots.

**Framing:** Standard (PCM31),  
CRC4 multiframe (PCM31CRC),  
standard with timeslot 16 CAS multiframe (PCM30),  
CRC4 multiframe with timeslot 16 CAS multiframe (PCM30CRC).

### Reported framing bits

**PCM31:** Remote alarm, spare bits (As per ITU-T G.704 Reference 2).

**PCM31CRC:** Remote alarm, remote end block alarm, spare bits, Si bits (As per ITU-T G.704 Reference 2).

**PCM30:** Remote alarm, remote CAS alarm, ABCD signaling bits, spare bits (As per ITU-T G.704 Reference 2).

## General Information

**PCM30CRC:** Remote alarm, remote CAS alarm, remote end block alarm, ABCD signaling bits, spare bits, Si bits (As per ITU-T G.704 Reference 2).

**Frame alignment 2 Mb/s:** As per ITU-T Rec. G.706 (Reference 3).

**Frame gain 2 Mb/s:** 1 Correct sequence of FAS-NFAS-FAS.

**Frame loss 2 Mb/s:** 3 consecutive incorrect FAS or NFAS words.

**Frame alignment 2 Mb/s CRC4:** As per ITU-T Rec. G.706 (Reference 3).

**Frame alignment 2 Mb/s CAS:** As per ITU-T Rec. G.732 (Reference 4).

**Frame gain 2 Mb/s CAS:** 1 correct CAS multiframe and the previous CAS word is not 0000.

**Frame loss 2 Mb/s CAS:** 2 consecutive errored CAS multiframe patterns or 16 frames with CAS word 0000.

### Input mode & signal conditioning

**Terminated:** 2.37 V unbalanced, 3.0V balanced.

**Equalization at f/2:** 6 dB.

**Monitor gain:** 20 dB, 26 dB, 30 dB.

**Monitor equalization at f/2:** 6 dB.

**Pattern gain:** 32 consecutive error free bits received.

**Pattern loss:**

**PRBS:** BER  $\geq$  20% for 10 consecutive 100 ms periods.

**Word:** BER  $\geq$  4%.

**Jitter tolerance:** As per ITU-T Rec G.823 (Reference 8).

### Voice channel monitor

**Frequency measurement range:** 300 Hz to 3400 Hz.

**Frequency measurement accuracy:**  $\pm 1$  Hz.

#### Level measurement accuracy

**-60 dB to -20 dB:**  $\pm 5$  dB.

**-20 dB to +3 dB:**  $\pm 1$  dB.

**Autosetup:** Detects and matches, if possible, the line rate framing and test pattern of an incoming signal.

**Test period:** Manual, single, delayed.

**Manual:** Start by pressing **START/STOP**, will continue until **START/STOP** is pressed.

**Single:** Fixed duration. Started by pressing **START/STOP** and stops when fixed duration has passed. Can be stopped sooner by pressing **START/STOP**.

**Delayed:** Fixed duration. Starts when user-selected date & time is reached and stops when fixed duration has passed. Can be stopped sooner by pressing

**START/STOP**.

## General Information

**Fixed periods (Single & Delayed):** 10 seconds, 1 minute, 15 minutes, 1 hour, User.  
**User periods (Single & Delayed):** 1 to 59 seconds, 1 to 59 minutes, 1 to 23 hours (Line voltage operation only), 1 to 99 days (Line voltage operation only).

**Alarms detected:** LOS, LOF, AIS, TS AIS, RDI, RDI MF, pattern loss, CAS multiframe loss. Jitter Unlocked (Option 002), and Jitter Over-range (Option 002).

**Alarm indicators:** Battery low, error, alarm, signal loss.

**Errors detected:** Bit, FAS, CRC, E-Bit, Code, Jitter Hits (Option 002).

### Round trip delay

**Accuracy:**  $\pm 1 \mu\text{s}$ .

**Resolution:**  $1 \mu\text{s}$ .

**Range:**  $1 \mu\text{s}$  to 1999.999 ms.

**Frequency measurement:** Input frequency displayed in Hz with 1 Hz resolution, frequency offset displayed in Hz and ppm.

**Accuracy:**  $\pm 4.6 \text{ ppm}$ .

## Advanced signal quality measurement (Option 001)

Allows jitter measurement, level measurement and pulse mask verification on received 2.048 Mb/s signals.

**Jitter measurement:** Jitter is measured on the received signal using the recovered clock of 2.048 Mb/s with up to  $\pm 50 \text{ ppm}$  of frequency offset.

**Measurement ranges:** Range 1.6 - 0 to 1.6 UI pk-pk; range 16 - 0 to 15.5 UI pk-pk.

**Measurement bandwidth:** Range 1.6 - 2 Hz to  $>100 \text{ kHz}$ , range 16 - 2 Hz to  $50 \text{ kHz}$ .

**Jitter peak results resolution:** 0.001 UI range 1.6, 0.01 UI range 16.

**Hit threshold resolution:** 0.01 UI range 1.6, 0.1 UI range 16.

**Peak measurement accuracy:** To ITU-T Recommendation O.171/O.172.

| Range  | Accuracy (peak)       | Accuracy (peak-to-peak) |
|--------|-----------------------|-------------------------|
| 1.6 UI | $\pm 5\% \pm X \pm Y$ | $\pm 5\% \pm X \pm 2Y$  |
| 16 UI  | $\pm 5\% \pm X \pm Y$ | $\pm 5\% \pm X \pm 2Y$  |

Where X is the receiver intrinsic jitter as described below, and Y is 0.01 UI for 1.6 UI range and 0.03 UI for 16 UI range.

## General Information

### Receiver intrinsic jitter:

| X                                |                              |                  |
|----------------------------------|------------------------------|------------------|
| 1.6 UI Range<br>Intrinsic Jitter | 16 UI Range Intrinsic Jitter |                  |
|                                  | Clock (all ones)             | PRBS             |
| 0.02 UI                          | 0.07 UI                      | 0.1 <sup>1</sup> |

1. Typically 0.05 UI after calibration.

The following additional intrinsic jitter may apply:

0.02 UI (typical) when using monitor gain.

0.01 UI (typical) when using equalization.

0.01 UI (typical) at temperatures outwith ambient.

Values are peak-to-peak jitter measured with LP and HP1 filter present.

**Internal filters:** To ITU-T Recommendation O.171/O.172.

Nominal 3dB corner frequencies

| HP1 (high pass) <sup>1</sup> | HP1 (high pass) | LP (low pass) |
|------------------------------|-----------------|---------------|
| 20 Hz                        | 18 kHz          | 100 kHz       |

1. Conforms to the mask limits specified in ITU-T O.172 Appendix IV.

**Pulse mask measurement:** 2.048 Mb/s signal must be in the level range -28 dB to +4 dB relative to the nominal level defined in ITU-T G.703 (Reference 1).

**Pulse width accuracy:** ±20 ns.

**Pulse width ratio:** 0.95 to 1.05.

**Pulse level ratio:** 0.95 to 1.05.

**Pass/fail test:** Signal must be within mask defined in G.703, Figure 15.

**Level measurement:** 2.048 Mb/s signal must be in the level range -28 dB to +4 dB relative to the nominal level defined in ITU-T G.703 (Reference 1).

**Resolution:** 1 dB.

**Level accuracy:**

**-10 dB to +4 dB:** ±1 dB.

**-20 dB to -10 dB:** ±2 dB.

**-36 dB to -20 dB:** ±3 dB.

## General Information

### Co-directional interface (Option 002)

Provides 64 kb/s transmit and receive interfaces as per ITU-T G.703.

#### Transmitter

**Rate:** 64 kb/s.

**Connector:** 3-pin Siemens, 120 $\Omega$  balanced.

**Line Code:** As per ITU-T G.703 section 1.2.1.1.5 (Reference 1).

**Mark level:** The pulse mask at the output will comply with ITU-T G.703 section 1.2.1.2 (Reference 3).

**Clock source:** Internal, external.

**Internal clock accuracy:**  $\pm 4.6$  ppm.

**External clock:** Divided-down version of a clock complying with ITU-T G.703 Section 10 (Reference 1).

**Error add:** Bit.

**Rate:** Single, 1 in  $10^3$ , 1 in  $10^4$ , 1 in  $10^5$ , 1 in  $10^6$ , 1 in  $10^7$ .

**Alarm Generation:** Loss of signal, octet loss, pattern loss.

#### Receiver

**Rate:** 64 kb/s.

**Connector:** 3-pin Siemens, 120 $\Omega$  balanced.

**Line code:** As per ITU-T G.703 section 1.2.1.1.5 (Reference 1).

**Operating level:** The pulse mask at the input will comply with ITU-T G.703 section 1.2.1.2 (Reference 3).

**Alarms detected:** Signal loss, octet loss, pattern loss.

**Measurement results:** Bit error count.



---

## **2 Performance Tests**

In this section you will find procedures for verifying the performance of HP ProBER 2.

## Performance Tests

---

### Introduction

The procedures given here test the electrical performance of HP ProBER 2 using as performance standards the Specifications listed in Section 1, General Information. Each test is self contained and, therefore, may be performed as a stand-alone test or as part of full instrument calibration.

### Equipment Required

Equipment required for the Performance Tests is listed below. Any equipment which meets or exceeds the critical specification of the equipment listed, may be substituted.

| Instrument              | Critical Specification  | Recommended Model   |
|-------------------------|---|---|
| Oscilloscope            | 400 MHz Bandwidth, 1 M $\Omega$ Input Termination   | HP 54520A Opt 001 or HP 54810A Opt 001  |
| Synthesizer             | Sinewave 1 kHz to 5 kHz<br>Amplitude +10 dBm  | HP 3335A Opt 010 (75 $\Omega$ ) or HP 3325B & HP 8657A with 50/75 $\Omega$ matching pad |
| Frequency Counter       | Range 0 to 5 MHz, 2 channels with accuracy <0.1 ppm. (Ratio Mode)   | HP 5325A Opt 010 or HP 53181A Opt 001   |
| Spectrum Analyzer       | Range 0 to 10 MHz   | HP 8560E  |
| BER/Jitter Generator    | 2.048 Mb/s Line Rate with PCM30 Framing, Jitter Frequency range 2 Hz to 100 kHz, Jitter Amplitude Range 0.5 UI to 16 UI | HP 37717C Opt A3K   |
| Converter               | 75 $\Omega$ Unbalanced to 120 $\Omega$ Balanced   | HP 15508C   |
| 75 $\Omega$ Termination | 0 to 200 MHz  | HP 15522-80010  |
| T Connector             | BNC to Dual BNC   | HP 1250-0781  |



## Performance Tests

### Performance Test Record

The results of the Performance Tests may be recorded on the performance test record at the end of this section. The results recorded at incoming inspection may be used for comparison during periodic maintenance, troubleshooting or after repair or adjustment.

### Calibration Cycle

This instrument requires periodic verification of performance. Depending on use and environmental conditions, the instrument should be checked approximately once a year, using these Performance Tests. Full calibration details are given starting on page 4-1.

### Adjustments

This product has no adjustable components. If it fails a performance test and is out of specification, you will need to replace the appropriate assembly if re-calibration does not solve the problem.

### Recall Default Settings

The Performance Tests require HP ProBER 2 to be set to a pre-defined (default) state at the beginning of each test.

- 1 Using the cursor control keys **▼**, **▲**, **◀** and **▶**, set up the **Other Inst. Settings** display as shown below.



|  |                |
|--|----------------|
| Menu   | Other          |
| Type:  | Inst. Settings |
| Overwrite Protection: <input type="checkbox"/> On  |                |
| 0 :Factory Default Settings                        |                |
| 1 :.....   |                |
| 2 :.....   |                |
| 3 :.....   |                |
| 4 :.....   |                |
| ? Select the required action on the selected store |                |
| Recall   |                |

- 2 Press **Recall** to recall the instrument default settings. The status display will indicate stored settings number 0 recalled.

## Performance Tests

### Instrument Reset (Cold Start)

If you cannot control HP ProBER 2 using the front panel keys, in other words the software has “hung”, perform an Instrument Reset (Cold Start).

- 1 Press and hold down the On/Off key  for at least 7 seconds.
- 2 To restore power, press  again. HP ProBER 2 will return to the Default settings but any data previously stored in memory will be lost.

---

## Self-Test

### Description

Self Test is run to verify the functionality of the instrument prior to carrying out the performance tests.

### Procedure

- 1 Select **MENU** **Other** **Selftest** to obtain the Selftest display.
- 2 Select **Auto Tests** . **All Tests** .
- 3 Connect the TRANSMIT port to the RECEIVE port, 75Ω to 75Ω or 120Ω to 120Ω.
- 4 Press **START/STOP** to run the selftest.  
While the tests are running, the **Test Name**, **Subtest Number** and **Test Status** are updated on the display to show the progress of the test.
- 5 If HP ProBER 2 is functioning correctly, after 3 minutes, **Overall Status** PASSED is displayed.  
If **Overall Status** FAIL is displayed, HP ProBER 2 should be returned to a service office for repair.

| Fail Number | Description     | Fail Number | Description |
|-------------|-----------------|-------------|-------------|
| 1xxxx       | CPU             | 5xxxx       | BER         |
| 2xxxx       | Real Time Clock | 6xxxx       | Pulse Mask  |
| 3xxxx       | Line Level      | 7xxxx       | Jitter      |
| 4xxxx       | Clock           | 8xxxx       | Delay       |

### Internal Transmitter Clocks

#### Specifications

| Bit Rate         | Specification            |
|------------------|--------------------------|
| 2.048 MHz        | 2.048 MHz $\pm$ 9.421 Hz |
| 64 kHz (Opt 002) | 64 kHz $\pm$ 0.3 Hz      |

#### Description

This test verifies that the PDH transmit data rates are within limits. These limits assume the instrument is within the annual calibration cycle. The Frequency Offset capability (deviation from Standard Bit Rate) is also tested here.

The test uses a Frequency Counter connected to the TRANSMIT port to measure the data rate on an **All 1's** pattern. This gives an indirect measure of the internal transmitter clock frequency as the data is clocked by the internal clock oscillator. *Because the Frequency Counter triggers from the positive pulses only, the frequency count will be half the selected data rate.*

#### Equipment Required

|  |                     |
|--|---------------------|
| Frequency Counter  | HP 5335A Option 010 |
| 75 $\Omega$ Termination                                    | HP 15522-80010      |
| T Connector  | HP 1250-0781        |
| 120 $\Omega$ /75 $\Omega$ Balanced to Unbalanced Converter | HP 15508C           |

#### Procedure

##### 2.048 Mb/s Interface

- 1 Recall the HP ProBER 2 default settings as shown on page 2-3 and on the **Tx/Rx Setup** display, select Frame Structure **Unframed** and Test Pattern **All 1's**.

## Performance Tests

- 2 Connect the Unbalanced TRANSMIT port to the Frequency Counter. Terminate the Frequency Counter input in  $75\Omega$  (use the T connector).
- 3 Set the Frequency Counter to:  
FUNCTION - FREQ A  
ATTEN - X10
- 4 Adjust the Frequency Counter ATTEN and trigger level to obtain a stable reading and ensure that the Frequency Counter reads between 1023995.39 Hz and 1024004.61 Hz.

### 64 kHz Interface (Option 002 Only)

- 5 On the **Tx/Rx Setup** display, set the Transmit Line Rate to **64 kb/s** with the Test Pattern set to **All 1's** and the Octet Timing to **Octet Off**.
- 6 Connect the Balanced TRANSMIT port to the Frequency Counter via the  $120\Omega/75\Omega$  Balanced to Unbalanced Converter. Terminate the Frequency Counter input in  $75\Omega$  (use the T connector).
- 7 Adjust the Frequency Counter trigger level to obtain a stable reading and ensure that the Frequency Counter reads between 31999.85 Hz and 32000.15 Hz.

### 2 Mb/s Frequency Offsets

- 8 On the **Tx/Rx Setup** display, select Transmit Line Rate **2 Mb/s**, Frame Structure **Unframed** and Test Pattern **All 1's**. Connect the unbalanced TRANSMIT port to the Frequency Counter. Terminate the Frequency Counter input in  $75\Omega$  (use the T connector).
- 9 On the **Test Setup** display, select **Freq Offset** and **OFFSET +50 ppm**. Adjust the Frequency Counter trigger level to obtain a stable reading and ensure that the Frequency Counter reads between 1024046.59 Hz and 1024055.8 Hz.
- 10 Select **OFFSET -50 ppm**, adjust the Frequency Counter trigger level to obtain a stable reading and ensure that the Frequency Counter reads between 1023944.02 Hz and 1023953.41 Hz.
- 11 Select **Edit**, set **OFFSET +100 ppm**, adjust the Frequency Counter trigger level to obtain a stable reading and ensure that the Frequency Counter reads between 1024097.79 Hz and 1024107.0 Hz.
- 12 Select **Edit**, set **OFFSET -100 ppm**, adjust the Frequency Counter trigger level to obtain a stable reading and ensure that the Frequency Counter reads between 1023893.0 Hz and 1023902.2 Hz.

## Performance Tests

---

### Transmitter Output

#### Specifications

**Pulse Shape:** As per ITU Rec. G.703.

**Pulse Amplitude:**

|                       |                  |
|-----------------------|------------------|
| <b>120Ω Balanced</b>  | 3.00 V $\pm$ 10% |
| <b>75Ω Unbalanced</b> | 2.37 V $\pm$ 10% |

#### Description

This test verifies that the transmitter output level and pulse shape meets the required ITU specification. The Unbalanced TRANSMIT port is connected to an Oscilloscope and the waveform is checked for amplitude and duty cycle at the nominal mid-points. The waveform shape is also checked by comparison with the special ITU masks.

---

#### NOTE

This performance test is written using the HP 54520A Oscilloscope with Option 001 - Telecom Masks Application. If any other Oscilloscope is used the keystrokes given in this procedure will not apply. The Positive pulse masks are contained in the ROOT directory of the Telecom Mask Application Disk and the Negative pulse masks are in the INV\_MASK directory.

---

#### Equipment Required

|  |                      |
|--|----------------------|
| <b>Oscilloscope</b>                              | HP 54520A Option 001 |
| <b>T Connector</b>                               | HP 1250-0781         |
| <b>75Ω Termination</b>                           | HP 15522-80010       |
| <b>120Ω/75Ω Balanced to Unbalanced Converter</b> | HP 15508C            |

#### Installing the Telecom Masks Option

- 1 Insert the disk containing the Telecom Mask into the Oscilloscope Disk Drive.
- 2 Press SHIFT (Blue Key) DISK.

## Performance Tests

- 3 Press **DIRECTORY** then **ROOT DIRECTORY** softkeys.

## Procedure

### Positive Pulse

- 1 Recall the HP ProBER 2 default settings as shown on page 2-3.
- 2 Press **Tx/Rx Setup** and set up the display as shown.

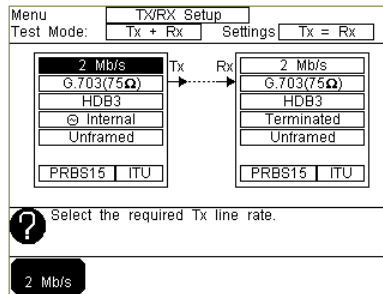

- 3 Connect the TRANSMIT unbalanced 75Ω port on HP ProBER 2 to the Oscilloscope CHAN 1, terminate in 75Ω.
- 4 Select CHAN 1 on the Oscilloscope and set to 1 MΩ input impedance.

### Load the Telecom Mask

- 5 On the Oscilloscope, use the following key sequence:
  - a/ SHIFT (Blue Key) APPLICATION.
  - b/ **TELECOM MASK/MASK** softkey.
  - c/ Use ENTRY/MEASURE control to select DS\_1E in the highlighted MSK FILES window.
  - d/ **LOAD SETUP 8 M1M2** softkey.

### Compare the Pulse with the Mask

- 6 On the Oscilloscope, use the following key sequence:
  - a/ RECALL 8.
  - b/ DEFINE MEAS.
  - c/ **COMPARE** softkey.
  - d/ **TEST ON** softkey.
  - e/ **M1M2** softkey.
  - f/ **AFTER FAIL CONTINUE** softkey.
  - g/ RUN.

## Performance Tests

- 7 The Oscilloscope will automatically display and compare an isolated positive pulse with the mask limits. A PASS message should appear on the Oscilloscope.

---

### NOTE

---

It may be necessary to visibly fit the waveform to the mask by adjusting the vertical position and horizontal delay to obtain a PASS on the Mask.

- 8 Measure the peak pulse amplitude at the mid pulse-width using the Oscilloscope and verify that this is between 2.133 V and 2.607 V.
- 9 Connect the TRANSMIT balanced 120 $\Omega$  port on HP ProBER 2 to the Oscilloscope CHAN 1 via the Balanced to Unbalanced Converter and select 120 $\Omega$  balanced on the **Tx/Rx Setup** display.
- 10 Terminate in 75 $\Omega$ , select CHAN 1 on the Oscilloscope and set to 1 M $\Omega$  input impedance.
- 11 Repeat Steps 6 through 8.

### Negative Pulse

- 12 On the Oscilloscope, use the following key sequence:
  - a/ SHIFT (Blue Key) DISK.
  - b/ **DIRECTORY** softkey.
  - c/ Use ENTRY/MEASURE control to highlight INV\_MASK.
  - d/ **CHANGE DIRECTORY** softkey.

### Load the Telecom Mask

- 13 On the Oscilloscope, use the following key sequence:
  - a/ SHIFT (Blue Key) APPLICATION.
  - b/ **TELECOM MASK/MASK** softkey.
  - c/ Use ENTRY/MEASURE control to select DS\_1E in the highlighted MSK FILES window.
  - d/ **LOAD SETUP 8 M1M2** softkey.

### Compare the Pulse with the Mask

- 14 On the Oscilloscope, use the following key sequence:
  - a/ RECALL 8.
  - b/ DEFINE MEAS.
  - c/ **COMPARE** softkey.
  - d/ **TEST ON** softkey.
  - e/ **M1M2** softkey.
  - f/ **AFTER FAIL CONTINUE** softkey.
  - g/ RUN.

## Performance Tests

**15** The Oscilloscope will automatically display and compare an isolated positive pulse with the mask limits. A PASS message should appear on the Oscilloscope.

---

### NOTE

---

It may be necessary to visibly fit the waveform to the mask by adjusting the Oscilloscope vertical position and horizontal delay to obtain a PASS on the Mask.

**16** Measure the peak pulse amplitude at the mid pulse-width using the Oscilloscope and verify that this is between 2.133 V and 2.607 V.

**17** Connect the TRANSMIT unbalanced 75Ω port on HP ProBER 2 to the Oscilloscope CHAN 1 and select 75Ω unbalanced on the **Tx/Rx Setup** display.

**18** Terminate in 75Ω, select CHAN 1 on the Oscilloscope and set to 1 MΩ input impedance.

**19** Repeat Steps 14 through 16.

---

## Frequency Measurement and Looped Clock

### Specifications

|                        |          |
|------------------------|----------|
| <b>Accuracy</b>        | ±7 ppm   |
| <b>Measured Offset</b> | ±100 ppm |

### Description

This test verifies that the HP ProBER 2 Receiver Frequency Measurement is within specified limits. These limits assume the instrument is within the annual calibration cycle.

Use a Synthesizer to generate a 3.5 V pk-pk sinewave at half the data rate. This is applied to the HP ProBER 2 Receiver Signal In port. As this signal corresponds to an *All Ones Ternary Signal*, the HP ProBER 2 receiver should sync up with no errors if set to an **All 1's** pattern. The Frequency Measurement accuracy of the HP ProBER 2 can be determined by comparison with the frequency displayed on the Synthesizer. Frequency Offset Measurement is also verified during this test as the HP ProBER 2 will display deviation from the expected Signal In frequency in ppm. The transmitter recovered clock function is also verified using the Frequency Counter in RATIO mode.



## Performance Tests

### Equipment Required

|                          |                           |
|--------------------------|---------------------------|
| <b>Synthesizer</b>       | HP 3335A Option 010 (75Ω) |
| <b>Frequency Counter</b> | HP 5335A Option 010       |

### Procedure

- 1 Recall the HP ProBER 2 default settings as shown on page 2-3.
- 2 Connect up the equipment as shown in the following diagram.

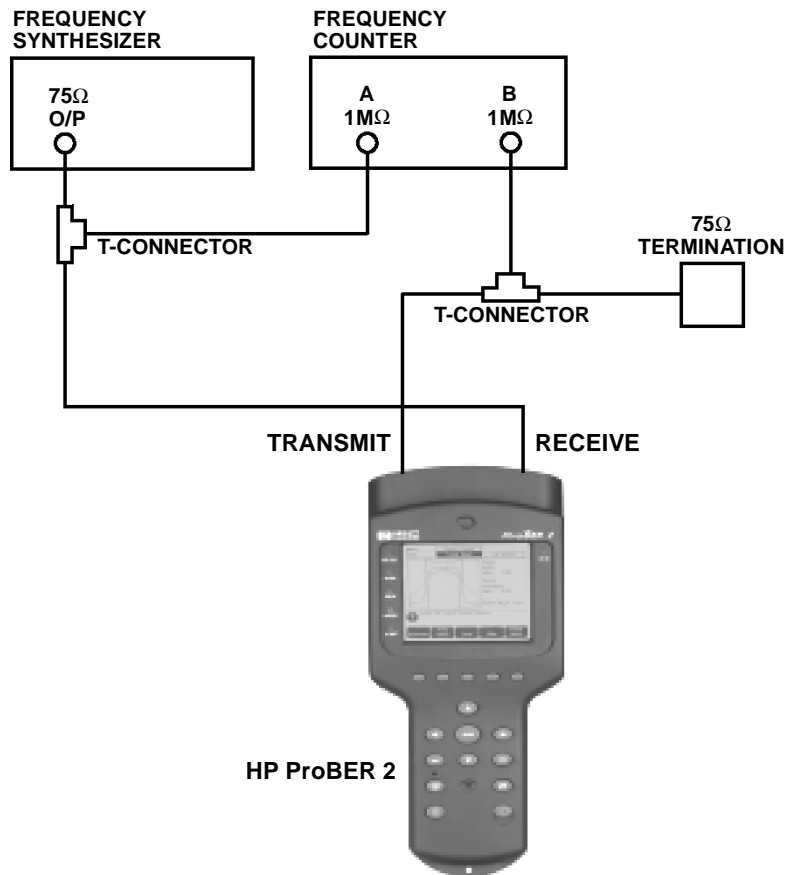

## Performance Tests

- 3 Press **Tx/Rx Setup** and set the display as below.

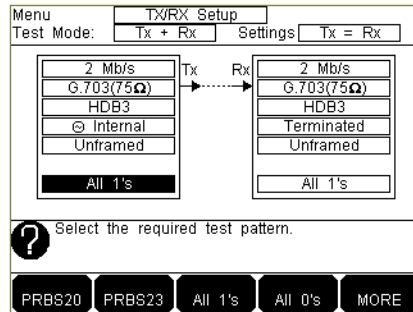

- 4 Set the Synthesizer to: FREQUENCY - 1024.000 kHz sinewave AMPLITUDE - +10 dBm.
- 5 Set the Frequency Counter to RATIO A/B.
- 6 Press **Results** and set up the display as shown below.

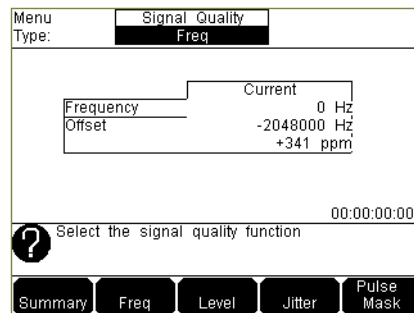

- 7 Verify that the FREQUENCY displayed is between 2047986 Hz and 2048014 Hz.
- 8 Verify that the Offset displayed is between +7 ppm and -7 ppm.
- 9 Set the Synthesizer frequency to 1024.102 kHz and verify that the frequency displayed on the **Results** display is between 2048190 Hz and 2048219 Hz.
- 10 Verify that the Offset displayed is between +93 ppm and +107 ppm. The Frequency Counter should read 1.00.
- 11 Set the Synthesizer frequency to 1023.898 kHz and verify that the frequency displayed on the **Results** display is between 2047781 Hz and 2047810 Hz.
- 12 Verify that the Offset displayed is between -93 ppm and -107 ppm. The Frequency Counter should read 1.00.

## Jitter Measurement

### Specifications

**Peak measurement accuracy:** To ITU-T Recommendation O.171/O.172.

| Range  | Accuracy (peak)       | Accuracy (peak-to-peak) |
|--------|-----------------------|-------------------------|
| 1.6 UI | $\pm 5\% \pm X \pm Y$ | $\pm 5\% \pm X \pm 2Y$  |
| 16 UI  | $\pm 5\% \pm X \pm Y$ | $\pm 5\% \pm X \pm 2Y$  |

Where X is the receiver intrinsic jitter as described below, and Y is 0.01 UI for 1.6 UI range and 0.03 UI for 16 UI range.

#### Receiver intrinsic jitter:

| X                                |                              |                  |
|----------------------------------|------------------------------|------------------|
| 1.6 UI Range<br>Intrinsic Jitter | 16 UI Range Intrinsic Jitter |                  |
|                                  | Clock (all ones)             | PRBS             |
| 0.02 UI                          | 0.07 UI                      | 0.1 <sup>1</sup> |

1. Typically 0.05 UI after calibration.

The following additional intrinsics may apply:

0.02 UI (typical) when using monitor gain.

0.01 UI (typical) when using equalization.

0.01 UI (typical) at temperatures outwith ambient.

Values are peak-to-peak jitter measured with LP and HP1 filter present.

**Internal filters:** To ITU-T Recommendation O.171/O.172.

Nominal 3dB corner frequencies

| HP1 (high pass) <sup>1</sup> | HP1 (high pass) | LP (low pass) |
|------------------------------|-----------------|---------------|
| 20 Hz                        | 18 kHz          | 100 kHz       |

1. Conforms to the mask limits specified in ITU-T O.172 Appendix IV.

## Performance Tests

### Description

This test verifies that the jitter receiver measures jitter to the required accuracy.

The test uses a BER/Jitter Generator to provide a 2 Mb/s line rate, accurate jitter source. The accuracy is achieved using the Bessel Null method measured on a Spectrum Analyzer.

### Equipment Required

|                             |                      |
|-----------------------------|----------------------|
| <b>BER/Jitter Generator</b> | HP 37717C Option A3K |
| <b>Spectrum Analyzer</b>    | HP 8560E             |
| <b>75Ω/50Ω Matching Pad</b> | HP 11825B            |

### Procedure

- 1 Recall the HP ProBER 2 default settings as shown on page 2-3.
- 2 Set the BER/Jitter Generator as follows:

|                         |            |
|-------------------------|------------|
| <b>Line Rate</b>        | 2.048 Mb/s |
| <b>Framing</b>          | PCM30      |
| <b>Pattern</b>          | All Ones   |
| <b>Line Code</b>        | HDB3       |
| <b>Line Termination</b> | 75Ω        |
| <b>Jitter Amplitude</b> | 0.77 UI    |
| <b>Jitter Frequency</b> | 2400 Hz    |

- 3 Connect the BER/Jitter Generator signal to the Spectrum Analyzer via the matching pad.

## Performance Tests

- 4 Set the Spectrum Analyzer as follows:

|                             |             |
|-----------------------------|-------------|
| <b>Centre Frequency</b>     | 2048 kHz    |
| <b>Frequency Span</b>       | 25 kHz      |
| <b>Reference Level</b>      | 0 dBm       |
| <b>Sweep Time</b>           | 1.0 seconds |
| <b>Video Bandwidth</b>      | 100 Hz      |
| <b>Resolution Bandwidth</b> | 300 Hz      |

- 5 Adjust the BER/Jitter Generator amplitude to obtain the first carrier null on the Spectrum Analyzer. The first carrier null occurs when the jitter is 0.77 UI.

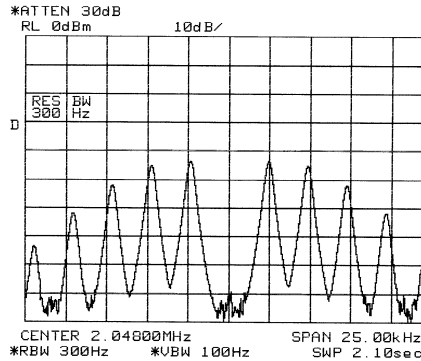

### Bessel Null Display

- 6 Connect the BER/Jitter Generator signal to the RECEIVE port on HP ProBER 2.
- 7 Choose **MENU** **Signal Quality** and set up the HP ProBER 2 display as shown below.

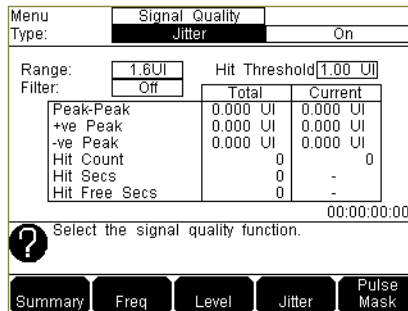

## Performance Tests

- 8 Check that the peak to peak jitter result is between 0.692 UI and 0.849 UI and the peak jitter result is between 0.336 UI and 0.434 UI.
- 9 Set the BER/Jitter Generator to generate 4.75 UI of jitter.
- 10 Connect the BER/Jitter Generator signal to the Spectrum Analyzer and adjust the jitter amplitude to obtain the fifth carrier null. The fifth carrier null should occur when the jitter is 4.75 UI.
- 11 Connect the BER/Jitter Generator signal to the RECEIVE port on HP ProBER 2.
- 12 Choose Range **16UI** and check that the peak to peak jitter is between 4.43 UI and 5.17 UI and the peak jitter is between 2.18 UI and 2.62 UI.
- 13 Disconnect all the test equipment.

## Performance Tests

### Performance Test Record

|                     |                      |
|---------------------|----------------------|
| <b>HP ProBER 2</b>  |                      |
| <i>Location:</i>    | <i>Serial No.:</i>   |
|                     | <i>Tested by:</i>    |
| <i>Temperature:</i> | <i>Certified by:</i> |
| <i>Humidity:</i>    | <i>Date:</i>         |

| Page No. | Test Description                   |                      | Result        |               |
|----------|------------------------------------|----------------------|---------------|---------------|
|          |                                    |                      | Min.          | Actual Max.   |
|          | <b>Self Test</b>                   |                      |               |               |
| 2-4      | Step 5:                            | All Tests            |               | Pass/<br>Fail |
|          | <b>Internal Transmitter Clocks</b> |                      |               |               |
| 2-6      | Step 4:                            | 2 Mb/s               | 1023995.39 Hz | 1024004.61 Hz |
| 2-6      | Step 7:                            | 64 kb/s              | 31999.85 Hz   | 32000.15 Hz   |
|          |                                    | Offset               |               |               |
| 2-6      | Step 9:                            | +50 ppm              | 1024046.59 Hz | 1024055.8 Hz  |
| 2-6      | Step 10:                           | -50 ppm              | 1023944.02 Hz | 1023953.41 Hz |
| 2-6      | Step 11:                           | +100 ppm             | 1024097.79 Hz | 1024107.0 Hz  |
| 2-6      | Step 12:                           | -100 ppm             | 1023893.0 Hz  | 1023902.2 Hz  |
|          | <b>Transmitter Output</b>          |                      |               |               |
| 2-9      | Step 7:                            | Unbal +ve Pulse Mask |               | Pass/<br>Fail |
| 2-9      | Step 8:                            | Unbal +ve Pulse Amp  | 2.133 V pk    | 2.607 V pk    |

| Page No. | Test Description                                |                      | Result     |               |            |
|----------|---|----------------------|------------|---------------|------------|
|          |   |                      | Actual     | Min.          | Max.       |
| 2-9      | Step 11:  | Bal +ve Pulse Mask   |            | Pass/<br>Fail |            |
| 2-9      | Step 11:  | Bal +ve Pulse Amp    | 2.133 V pk |               | 2.607 V pk |
| 2-10     | Step 15:  | Bal -ve Pulse Mask   |            | Pass/<br>Fail |            |
| 2-10     | Step 16:  | Bal -ve Pulse Amp    | 2.133 V pk |               | 2.607 V pk |
| 2-10     | Step 19:  | Unbal -ve Pulse Mask |            | Pass/<br>Fail |            |
| 2-10     | Step 19:  | Unbal -ve Pulse Amp  | 2.133 V pk |               | 2.607 V pk |
|          | <b>Frequency Measurement &amp; Looped Clock</b> |                      |            |               |            |
| 2-12     | Step: 7   | Frequency            | 2047986 Hz |               | 2048014 Hz |
| 2-12     | Step: 8   | Offset               | -7 ppm     |               | +7 ppm     |
| 2-12     | Step: 9   | Frequency (+100 ppm) | 2048190 Hz |               | 2048219 Hz |
| 2-12     | Step:10   | Offset (+100 ppm)    | +93 ppm    |               | +107 ppm   |
| 2-12     | Step:11   | Frequency (-100 ppm) | 2047781 Hz |               | 2047810 Hz |
| 2-12     | Step:12   | Offset (-100 ppm)    | -93 ppm    |               | -107 ppm   |
|          | <b>Jitter Measurement</b>                       |                      |            |               |            |
| 2-16     | Step: 8   | 1.6UI Pk-Pk          | 0.692 UI   |               | 0.849 UI   |
| 2-16     | Step: 8   | 1.6UI Peak           | 0.336 UI   |               | 0.434 UI   |
| 2-16     | Step:12   | 15.5UIPk-Pk          | 4.43 UI    |               | 5.17 UI    |
| 2-16     | Step:12   | 15.5UI Peak          | 2.18 UI    |               | 2.62 UI    |



---

## 3 Repair

This section includes the service policy, details of how to troubleshoot HP ProBER 2, how to replace the battery and the various board assemblies, and a list of replaceable parts.

## Repair

---

### Repair Policy

The repair policy for HP ProBER 2 is:

- Replacement of a faulty battery.
- Return to a Hewlett-Packard Service Office for repair.

---

### WARNING

**These servicing and repair instructions are for use by service-trained personnel only**

---

---

### Block Diagrams

HP ProBER 2 is a combined transmitter and receiver. It offers 2 Mb/s, n x 64 kb/s, 64 kb/s codirectional measurement facilities for signal quality, pulse mask, jitter, frequency and level.

The instrument consists of a processor board, a power supply board, a keypad and a graphic display. The vast majority of the generation and measurement is performed by the processor board and the interaction of its constituent parts are shown in the block diagrams below; voice frequency generation is the exception and this is performed by the power supply card.

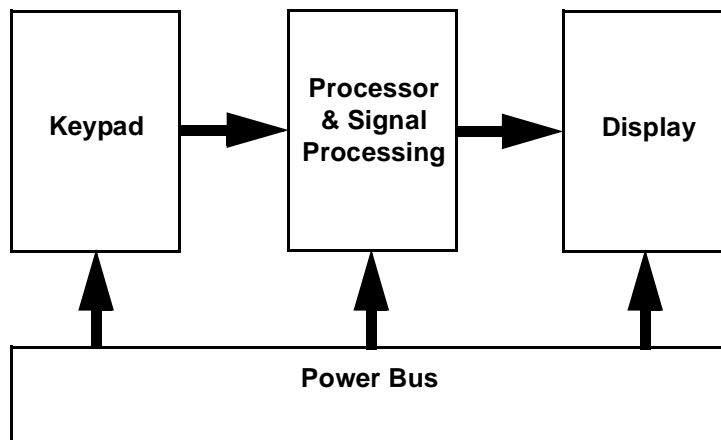

# Repair

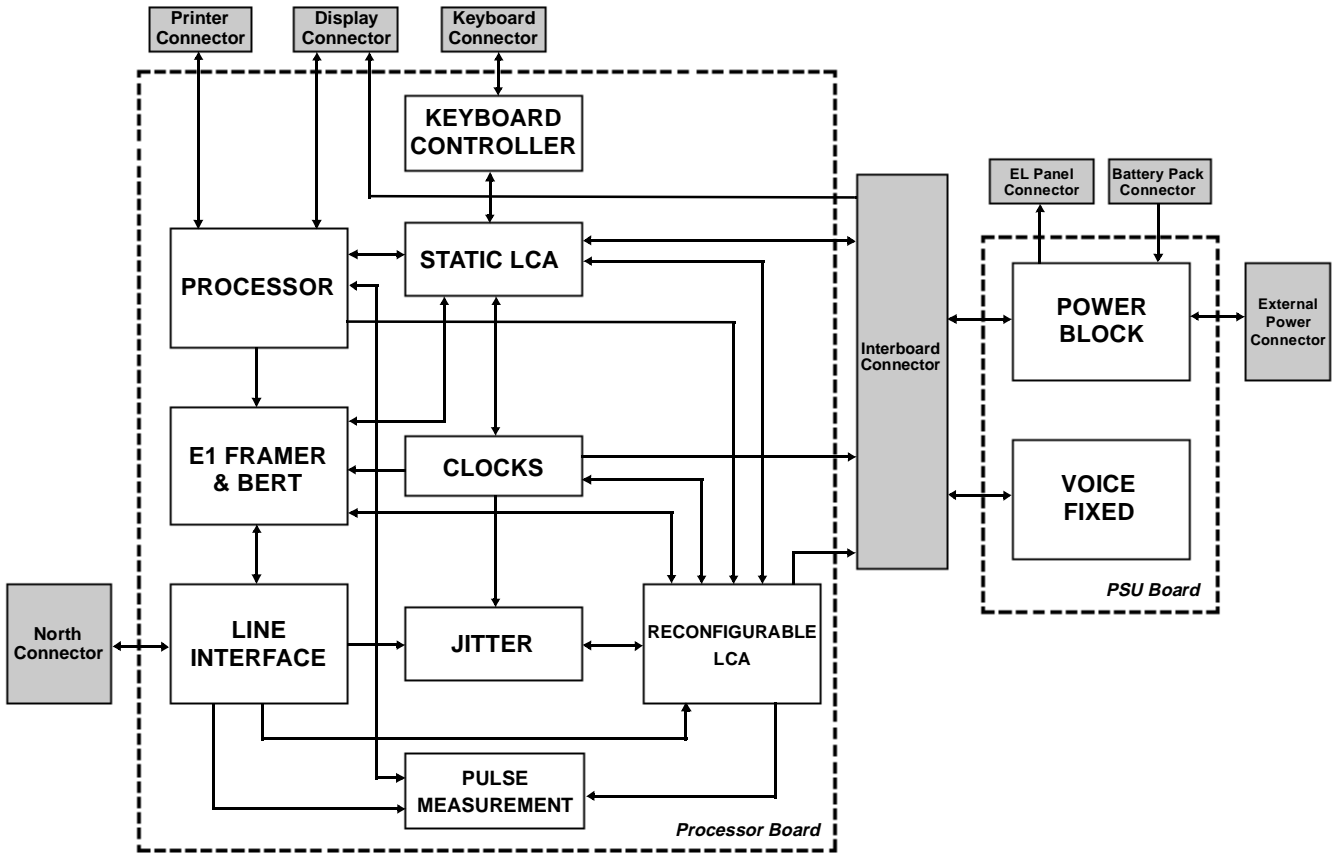

## Repair

---

### Troubleshooting

The following procedures are given as a guide to troubleshooting HP ProBER 2. Apart from replacing the battery, all other repair procedures should be carried out by fully qualified Hewlett-Packard service personnel. For help in identifying the various parts of the instrument, see "Replacing the Board Assemblies", page 3-8.

| Fault   | Troubleshooting  |
|---|--|
| DC IN LED unlit when external power applied.  | <b>Cause:</b><br>PSU board or Keymat.<br><b>Action:</b><br>1. Change the PSU board.<br>If DC IN LED still unlit, suspect the Keymat.   |
| Internal LED not flashing at Transmit port.   | <b>Cause:</b><br>LCA PROM inserted incorrectly, PSU board or Processor board.<br><b>Action:</b><br>1. Check the LCA PROM.<br>Insert LCA PROM correctly (if required). If internal LED still not flashing go to step 2.<br>2. Change the PSU board.<br>If internal LED still not flashing, change the Processor board.  |
| Internal LED flashing at Transmit port but no display.  | <b>Cause:</b><br>Display and associated cable or Processor board faulty.   |
| Internal LED flashing at Transmit port with the display visible but no action on a key press. | <b>Cause:</b><br>Hung Processor or Keymat.<br><b>Action:</b><br>1. Perform a "Hold Power Off" reset by holding down Power ON/OFF button for 7 seconds.<br>2. Power up the instrument.<br>If the same fault persists, suspect the Processor board.<br>If responsive to a key press go to step 3.<br>3. Perform manual keyboard test.<br>If this test fails, suspect the Keymat. |

## Repair

| Fault  | Troubleshooting  |
|--|--|
| No Serial Port activity.   | <p><b>Cause:</b><br/>Processor board faulty.</p>   |
| No Tx signal with PRBS or fixed pattern.   | <p><b>Cause:</b><br/>Processor board, or North connector assembly or cable faulty. Or <b>Rx only</b> Test Mode selected.</p>   |
| No TX signal with VF tone pattern.   | <p><b>Cause:</b><br/>PSU board, Processor board, or North connector assembly or cable.</p> <p><b>Action:</b><br/>1. Change the TX pattern setting to VF tone. If no Tx signal, suspect the PSU board.</p>  |
| No speaker output.   | <p><b>Cause:</b><br/>PSU board, Processor board, or Keymat faulty.</p> <p><b>Action:</b><br/>1. Change the TX pattern setting to VF tone. If no speaker output, change the PSU board. If there is still no speaker output, suspect the Keymat.<br/>2. Change the TX pattern setting to PRBS, select Beep on Error and generate a <math>1 \times 10^{-3}</math> errors. If there is still no speaker output, suspect the Processor board.</p> |
| Instrument switches off soon after reaching the Tx/Rx page.                          | <p><b>Cause:</b><br/>Flat battery.</p> <p><b>Action:</b><br/>Apply external power for 24 hours.</p>  |
| Instrument switches off soon after reaching the Tx/Rx page with a "charged" battery. | <p><b>Cause:</b><br/>Battery or PSU board faulty.</p> <p><b>Action:</b><br/>Apply external power and listen for "buzz" sound from the instrument in quiet conditions. If there is no "buzz" sound, suspect the PSU board.</p>  |

## Repair

| Fault  | Troubleshooting  |
|--|--|
| Signal loss when unit is in loopback with a good Tx. | <b>Cause:</b><br>Processor board or North connector assembly faulty. |
| Manual display test fails                            | <b>Cause:</b><br>Display faulty.                                     |
| Manual LED test fails.                               | <b>Cause:</b><br>Keymat faulty.                                      |
| Back light fails.                                    | <b>Cause:</b><br>Battery, Display or PSU board faulty.               |

---

## Replacing the Battery

HP ProBER 2 contains a rechargeable Nickel-Metal Hydride battery pack which can be replaced in the event of failure.

---

### WARNING

---

**To prevent exposure to hazardous voltages, ensure that HP ProBER 2 is switched off and disconnected from the charger before replacing the battery.**

---

### CAUTION

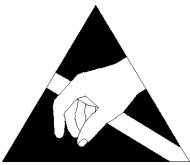

When replacing the battery, ensure that you are grounded to bring you and the instrument to the same static potential.

HP ProBER 2 contains components sensitive to electrostatic discharge.

To prevent component damage, carefully follow the handling precautions, see "ESD Precautions", page 1-8.

- 1 Ensure that HP ProBER 2 is switched off and disconnected from the charger.
- 2 With HP ProBER 2 lying face down on the bench, remove the two rubber feet from the South end of the clam shell. For help in identifying the various parts of the instrument, see "Replacing the Board Assemblies", page 3-8
- 3 Remove the 6 size 10 TORX retaining screws from the lower clam shell and lift off the lower clam shell.

## Repair

- 4 Unplug the battery from the power supply board as shown in the photograph and remove the 3 size 10 TORX retaining screws from the battery retaining plate.

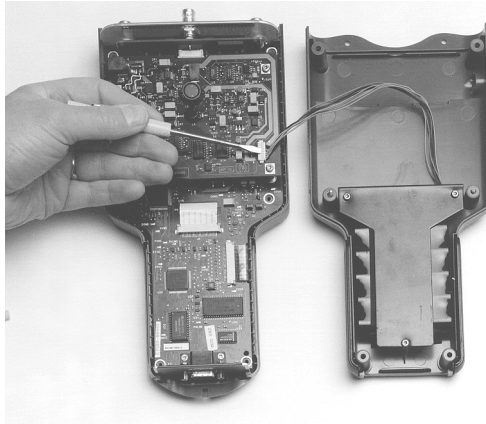

- 5 Remove the retaining plate and keep the foam packaging for re-use.

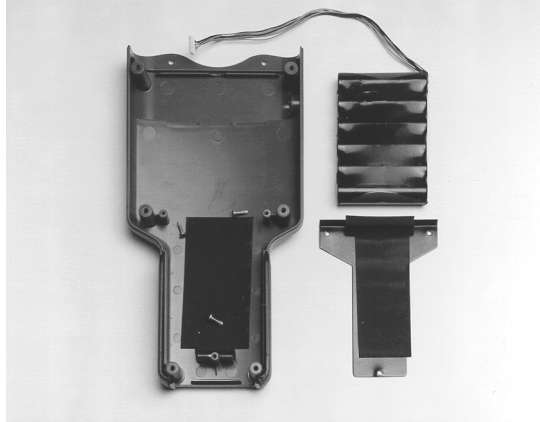

- 6 After removing the old one, insert the new battery and replace the retaining plate along with the foam packaging.
- 7 Replace and tighten the 3 TORX retaining screws.
- 8 Reconnect the battery to the power supply board.
- 9 Carefully re-locate the lower clam shell, ensuring that the RF gasket, rubber grips and North and South connector boards are properly located.

## Repair

- 10 Replace and tighten the 6 TORX retaining screws. Turn the screws anticlockwise at first to locate the threads, then tighten as normal; the threads are easily stripped.
- 11 Replace the rubber feet.
- 12 Insert charger into socket and commence charging the new battery.
- 13 Dispose of the faulty battery in the approved manner.

---

### WARNING



**CONTAINS NICKEL-METAL HYDRIDE.  
BATTERY MUST BE RECYCLED OR  
DISPOSED OF PROPERLY.**

---

## Replacing the Board Assemblies

To replace any of the board assemblies in HP ProBER 2, use the following procedures:

---

### WARNING

**To prevent exposure to hazardous voltages, ensure that HP ProBER 2 is switched off and disconnected from the charger before replacing any board assemblies.**

---

### CAUTION

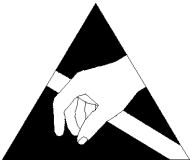

When replacing the boards, ensure that you are grounded to bring you and the instrument to the same static potential.

HP ProBER 2 contains components sensitive to electrostatic discharge.

To prevent component damage, carefully follow the handling precautions, see "ESD Precautions", page 1-8.



## Repair

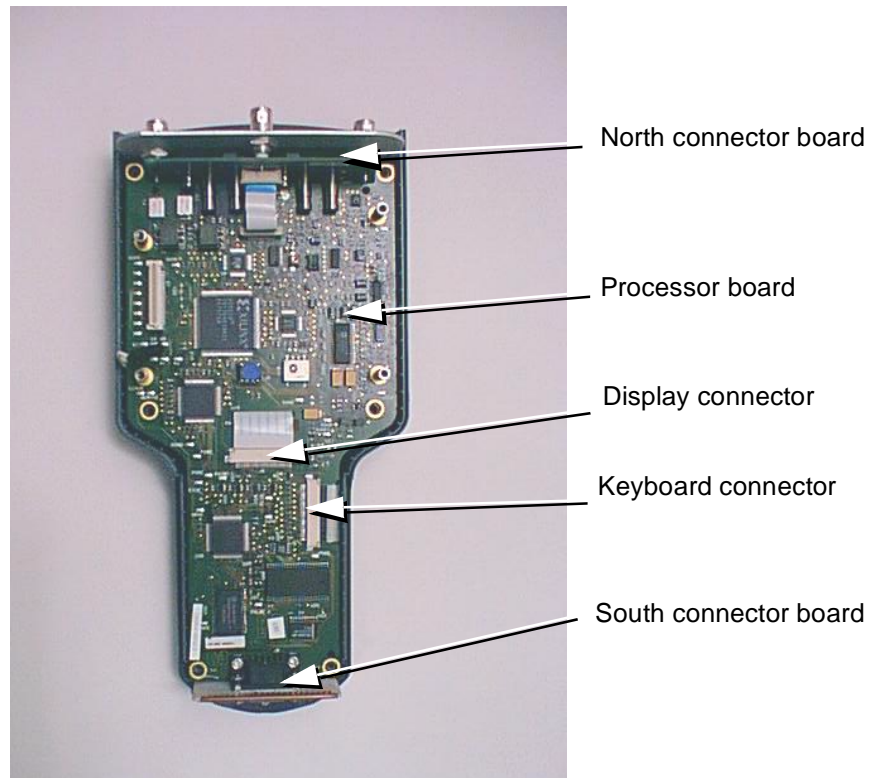

### Replacing the Power Supply Board

- 1 Ensure that HP ProBER 2 is switched off and disconnected from the charger.
- 2 With HP ProBER 2 lying face down on the bench, remove the two rubber feet from the South end of the clam shell.
- 3 Remove the 6 size 10 TORX retaining screws from the lower clam shell and lift off the lower clam shell.
- 4 Unplug the battery from the power supply board by pulling gently on the cable.
- 5 Remove the 4 size 10 TORX retaining screws at the corners of the power supply board. Note carefully the position of the copper earthing strip.
- 6 Gently pull apart the power supply board from the main processor assembly.
- 7 Tilt the power supply board so that it is hinged by two white wires on the left hand side of the board.

## Repair

- 8 Press down on the top of the connector for the white wires and pull the power supply board away.
- 9 Replace the power supply board and reconnect the white wires.
- 10 Swing the board back to the horizontal position and align the retaining holes with the stand-offs. Push the boards together. Note that the copper earthing strip is located at the top left hand corner, looking from South to North.
- 11 Replace and tighten the 4 TORX retaining screws.
- 12 Reconnect the battery to the power supply board.
- 13 Carefully re-locate the lower clam shell, ensuring that the RF gasket, rubber grips and North and South connector boards are properly located.
- 14 Replace and tighten the 6 TORX retaining screws. Turn the screws anticlockwise at first to locate the threads, then tighten as normal; the threads are easily stripped.
- 15 Replace the rubber feet.

## Replacing the Processor Board

---

### NOTE

---

If Option 002 has been supplied (check the serial number plate on the lower clam shell), then this option will have to be enabled after replacing the processor board, see "Enabling Option 002", page 4-3.

- 1 Ensure that HP ProBER 2 is switched off and disconnected from the charger.
- 2 With HP ProBER 2 lying face down on the bench, remove the two rubber feet from the South end of the clam shell.
- 3 Remove the 6 size 10 TORX retaining screws from the lower clam shell and lift off the lower clam shell.
- 4 Unplug the battery from the power supply board by pulling gently on the cable.
- 5 Remove the 4 size 10 TORX retaining screws at the corners of the power supply board. Note carefully the position of the copper earthing strip.
- 6 Gently pull apart the power supply board from the main processor assembly.
- 7 Tilt the power supply board so that it is hinged by two white wires on the left hand side of the board.
- 8 Press down on the top of the connector for the white wires and pull the power supply board away.

## Repair

- 9** Disconnect the cable to the North connector board by lifting the white plastic retaining catches and gently pulling the cable. Then lift out the North connector board.
- 10** Disconnect the cable to the display assembly by pushing forward the retaining catches on the white plastic collar and gently pulling the cable (located in the middle of the processor board).
- 11** Disconnect the keyboard cable at the right hand side of the processor board by pushing forward the retaining catches on the white plastic collar and gently pulling the cable. Tilt the processor board towards the connector for easier retraction.
- 12** Lift out the processor board and replace with the new board.
- 13** Reconnect the keyboard cable to the processor board. It's easier if you tilt the processor board towards the connector. The connector retaining catches must be pushed forward before the cable can be connected and then retracted to lock the cable in position.
- 14** Push the cable through the slot in the middle of the processor board and then reconnect the cable to the display assembly.
- 15** Replace the North connector board in its slot and then reconnect its cable to the processor board.
- 16** Reconnect the white wires to the power supply board.
- 17** Swing the power supply board back to the horizontal position and align the retaining holes with the stand-offs. Push the boards together. Note that the copper earthing strip is located at the top left hand corner, looking from South to North.
- 18** Replace and tighten the 4 TORX retaining screws.
- 19** Reconnect the battery to the power supply board.
- 20** Carefully re-locate the lower clam shell, ensuring that the RF gasket, rubber grips and North and South connector boards are properly located.
- 21** Replace and tighten the 6 TORX retaining screws. Turn the screws anticlockwise at first to locate the threads, then tighten as normal; the threads are easily stripped.
- 22** Replace the rubber feet.

## Repair

### Replacing the Display Assembly

- 1 Ensure that HP ProBER 2 is switched off and disconnected from the charger.
- 2 With HP ProBER 2 lying face down on the bench, remove the two rubber feet from the South end of the clam shell.
- 3 Remove the 6 size 10 TORX retaining screws from the lower clam shell and lift off the lower clam shell.
- 4 Unplug the battery from the power supply board by pulling gently on the cable.
- 5 Remove the 4 size 10 TORX retaining screws at the corners of the power supply board. Note carefully the position of the copper earthing strip.
- 6 Gently pull apart the power supply board from the main processor assembly.
- 7 Tilt the power supply board so that it is hinged by two white wires on the left hand side of the board.
- 8 Press down on the top of the connector for the white wires and pull the power supply board away.
- 9 Disconnect the cable to the North connector board by lifting the white plastic retaining catches and gently pulling the cable. Then lift out the North connector board.
- 10 Disconnect the cable to the display assembly by pushing forward the retaining catches on the white plastic collar and gently pulling the cable (located in the middle of the processor board).
- 11 Disconnect the keyboard cable at the right hand side of the processor board by pushing forward the retaining catches on the white plastic collar and gently pulling the cable. Tilt the processor board towards the connector for easier retraction.
- 12 Lift out the processor board.
- 13 Remove the display assembly by undoing the 4 size 6 TORX screws.
- 14 Replace the display. Replace and tighten the 4 TORX screws.
- 15 Replace the processor board.
- 16 Reconnect the keyboard cable to the processor board. It's easier if you tilt the processor board towards the connector. The connector retaining catches must be pushed forward before the cable can be connected and then retracted to lock the cable in position.
- 17 Push the cable through the slot in the middle of the processor board and then reconnect the cable to the display assembly.

## Repair

- 18 Replace the North connector board in its slot and then reconnect its cable to the processor board.
- 19 Reconnect the white wires to the power supply board.
- 20 Swing the power supply board back to the horizontal position and align the retaining holes with the stand-offs. Push the boards together. Note that the copper earthing strip is located at the top left hand corner, looking from South to North.
- 21 Replace and tighten the 4 TORX retaining screws.
- 22 Reconnect the battery to the power supply board.
- 23 Carefully re-locate the lower clam shell, ensuring that the RF gasket, rubber grips and North and South connector boards are properly located.
- 24 Replace and tighten the 6 TORX retaining screws. Turn the screws anticlockwise at first to locate the threads, then tighten as normal; the threads are easily stripped.
- 25 Replace the rubber feet.

---

## Replaceable Parts

| Description  | HP Part Number |
|--|----------------|
| Battery Charger  | 0950-3412      |
| Bottom Clam  | E7580-40006    |
| Battery  | E7580-60010    |
| Battery Strap  | E7580-40005    |
| Display  | 2090-0371      |
| North Connector Board                                    | E7580-60007    |
| Printer/RS232 Board                                      | E7580-60015    |
| Power Supply Board                                       | E7580-60003    |
| Top Clam + Keys + Display                                | E7580-60005    |
| Top Clam + Keys (No Display)                             | E7580-60016    |
| Microprocessor Board (Standard)                          | E7580-60014    |
| Microprocessor Board<br>(Option 001, 002 or 001 and 002) | E7580-60002    |



---

## **4 Calibration and Self-Test**

This section includes details of how to calibrate HP ProBER 2 and how to perform a self-test.

### Pre-Calibration Procedure

After repair, HP ProBER 2 should be re-calibrated but first the serial number, time and date should be entered and Option 002 (if ordered) enabled as follows.

#### Erasing Existing Calibration Data

Existing calibration data can be erased if necessary, as follows:

- 1 To make the debug page available, press the following keys, in this order: **MENU**, **▲**, **MENU**, **▲**, **▶**, **▼** then **◀**.
- 2 The debug page is now accessible through the **Other** menu. Select **More**, **Other**, **▼**, **More**, **More**, **Debug**.
- 3 Then select **▶**, **Misc**.
- 4 Press **▼** four times to highlight the **Erase Calibration** field.
- 5 Erase the existing calibration data by pressing **Erase**.
- 6 Power cycle HP ProBER 2.

#### Entering the Serial Number

After replacement of the processor board, the correct serial number must be programmed back into HP ProBER 2 using a PC.

- 1 Connect the Serial A (or Com A) port on your PC to the Printer port on HP ProBER 2 using either a null modem cable (part number 24542U).
- 2 Power on HP ProBER 2 and choose **MENU**, **More**, **Other**, **▼**, **More**, **Options** to display the Options page.
- 3 On the PC, choose Start, Programs, Accessories, Hyperterminal, HyperTerminal.
- 4 You may be asked if you want to install a modem at this stage. If so, answer No.
- 5 Then enter your name and click OK.
- 6 Details of the connection will be displayed. Ensure that COM 1 is chosen as the connection.



## Calibration and Self-Test

- 7 The Port Settings are then displayed. These should be:  
Bits per second: 9600  
Data bits: 8  
Parity: None  
Stop bits: 1  
Flow control: Xon/Xoff.
- 8 On the PC, type the following string:  
:SYST:SER GBxxxxxxx  
where xxxxxxx is the serial number of HP ProBER 2 and then press Enter. Note that you will not be able to see the string on the PC screen. You will see it displayed on the screen of HP ProBER 2. The correct serial number to enter is shown on the label on the lower shell of HP ProBER 2.  
(Note: one way of seeing what you are typing is to type the character string on a conventional word processor and then copy and paste it into the hyperterminal.)
- 9 Disconnect the PC from HP ProBER 2.

## Enabling Option 002

After replacement of the processor board, the Option 002 (if ordered with HP ProBER 2) must be re-enabled but first, a codeword must be obtained from your HP Service Office. Telephone numbers and addresses are listed at the back of this Service Manual. When you contact the office, please have a note of the serial number and the options enabled. This can be found on the instrument serial plate. Once you have the codeword, enable the options as follows:

- 1 Power on HP ProBER 2 and press the following keys, in this order: **MENU**, **▲**, **MENU**, **▲**, **▼**, **▶**, **◀**, **More**, **Other**, **▼**, **More**, **Options**, **▶** then **Enter**.
- 2 Use the **▲**, **▼**, **▶** and **◀** cursor keys to enter the codeword and the **INS** and **DEL** softkeys to insert or delete extra digits as required. Then press **ENTER**.
- 3 Check the options field to confirm that the correct ones are enabled.

## Setting the Time and Date

- 1 Power on HP ProBER 2 and choose **MENU**, **More**, **Other**, **▼**, **More**, **Time/Date** to obtain the Time and Date display.
- 2 Move the cursor to **Date** and enter the correct date using **EDIT**, **▲**, **▼**, **◀** and **▶**. Press **ENTER** to action your edits or press **Cancel** to escape.
- 3 Move the cursor to **Time** and enter the correct date using **EDIT**, **▲**, **▼**, **◀** and **▶**. Press **ENTER** to action your edits or press **Cancel** to escape.

---

### Calibration

---

#### NOTE

Allow HP ProBER 2 to warm up for at least 60 minutes before calibration. Warm-up should be performed on battery power only, not on external power. The battery life should be checked prior to calibration. More than 2 hours battery life remaining is required for warm-up and calibration.

---

### Test Equipment

The following test equipment is required for calibrating HP ProBER 2.

| Calibration | Test Equipment  |
|-------------|---|
| TCXO        | Function Generator capable of generating a 2.048 MHz TTL clock and accepting the site 10 MHz frequency reference. |
| Line Level  | 2 Mb/s reference signal (e.g. from HP 37721A Digital Transmission Analyzer) and calibrated attenuator.            |
| Pulse Mask  | 2 Mb/s reference signal (e.g. from HP 37721A Digital Transmission Analyzer) and calibrated attenuator.            |
| Jitter      | Self contained.   |
| Voice TX    | Self contained.   |

### Accessing the Calibration Menu

Access HP ProBER 2 calibration page as follows:

- 1 Press the following keys, in this order: **MENU**, **▲**, **MENU**, **▲**, **◀**, **▼**, **▶**, **More**, **Other**, **▼**, **More**, **Calibration**, then **▶**.
- 2 Select the calibration required by pressing the appropriate softkey and then press **▼** followed by **Go!**.

## Calibration and Self-Test

### Calibration Test Equipment Setup

#### TXCO

Set up the Function Generator (connected to the site 10 MHz frequency reference) to provide a 2.048 MHz TTL clock signal. Connect the output of the function generator to EXT CLOCK IN on HP ProBER 2.

#### Line Level

Using an HP 37721A Digital Transmission Analyzer or similar, set up as shown in the table below.

| Parameter       | Setting        |
|-----------------|----------------|
| BIT RATE        | 2 Mb/s         |
| INTERFACE       | CODED          |
| TX CLOCK SOURCE | INTERNAL       |
| TX CLOCK OFFSET | OFF            |
| PATTERN         | PRBS15         |
| TERMINATION     | 75Ω UNBALANCED |
| CODE            | HDB3           |

Connect the HP 37721A 2 Mb/s unbalanced transmit port to HP ProBER 2 RECEIVE port through a calibrated attenuator and follow the on-screen instructions.

#### Pulse Mask

Using an HP 37721A Digital Transmission Analyzer or similar, set up as shown in the following tables.

| Parameter       | Setting  |
|-----------------|----------|
| BIT RATE        | 2 Mb/s   |
| INTERFACE       | CODED    |
| TX CLOCK SOURCE | INTERNAL |

## Calibration and Self-Test

| Parameter       | Setting        |
|-----------------|----------------|
| TX CLOCK OFFSET | OFF            |
| PATTERN         | 1000           |
| TERMINATION     | 75Ω UNBALANCED |
| CODE            | HDB3           |

Connect the HP 37721A 2 Mb/s unbalanced transmit port to HP ProBER 2 RECEIVE port through a calibrated attenuator. Follow the on-screen instructions.

### Jitter and Voice TX

Connect the TRANSMIT port to the RECEIVE port on HP ProBER 2. No external calibration equipment is required. Follow the on-screen instructions.

---

## Self-Test

Access HP ProBER 2 Self-Test page as follows:

- 1 Power on HP ProBER 2 and press the following keys, in this order: **MENU**, **More**, **Other**, **▼**, then **Self Test**.
- 2 Then select **Manual Tests** and follow the on-screen instructions.
- 3 Select **Auto Tests**. Connect the Transmit and Receive ports using a 75Ω cable and follow the on-screen instructions for the test chosen.

### Speaker/Microphone Test

Access HP ProBER 2 Talk/Listen page from the Self-Test page as follows:

- 1 Choose **MENU**, **More**, **Other**, **▼**, then **Talk/Listen**.
- 2 Then select **▶**, **Enabled** then **▼** to highlight the **Volume** field.
- 3 Increase the volume using the softkeys until a feedback 'howl' is heard. If no 'howl' is audible once the maximum volume (10) is reached, press a finger to the microphone aperture just below the **▼** key. If feedback 'howl' is still not audible, the unit has **FAILED**.

## Index

### A

- Additional Precautions for Service Engineers 1-8
- Adjustments 2-3
- Altitude
  - storage 1-5
- Anti-Static Products 1-9
- Assistance 1-4
- Australian EMC Regulations
  - Compliance with 1-10

### B

- Battery Replacement 3-6
- Block Diagrams 3-2
- Board Assembly Replacement 3-8

### C

- Cabinet Cleaning 1-9
- Calibration 4-4
- Calibration Cycle 2-3
- Calibration Menu 4-4
- Calibration Test Equipment Setup 4-5
- Certification 1-4
- Cleaning cabinet 1-9
- Cold Start 2-4
- Compliance, Statement of 1-10

### D

- Dimensions 1-6

### E

- Electromagnetic Compatibility 1-10
- Enabling Option 002 4-3
- Entering the Serial Number 4-2
- Environment
  - Storage and Shipment 1-5
- Equipment Required 2-2
- Erasing Existing Calibration Data 4-2

### F

- Frequency Measurement and Looped Clock 2-10

### I

- Instrument Reset 2-4
- Instrument Serial Number 1-4
- Internal Transmitter Clocks 2-5

### J

- Jitter Measurement 2-13

### M

- Maintenance by the Operator 1-9

### N

- Noise Declaration (German) 1-10

### O

- Operator's Maintenance 1-9
- Original Packaging 1-5
- Other Packaging 1-5

### P

- Packaging 1-5
- Performance Test Record 2-17
- Pre-Calibration Procedure 4-2

### R

- Recall Default Settings 2-3
- Repackaging for Shipment 1-5
- Repair Policy 3-2
- Replaceable Parts 3-13
- Replacing the Battery 3-6
- Replacing the Board Assemblies 3-8
- Responsibilities of the Customer 1-3
- Restricted Rights Legend 1-4

## Index

### S

Safety Information 1-6  
Safety Precautions for the Operator 1-6  
Safety Symbols 1-7  
Self-Test (Calibration) 4-6  
Self-Test (Performance Tests) 2-4  
Serial Number Plate 1-5  
Setting the Time and Date 4-3  
Specifications 1-12  
Statement of Compliance 1-10  
Storage and Shipment 1-5  
Symbols, Safety 1-7

### T

Tagging for Service 1-5  
Temperature  
    storage 1-5  
Transmitter Output 2-7  
Troubleshooting 3-4

### W

Warranty 1-2  
Weight 1-6